

EE309 Advanced Programming Techniques for EE

Lecture 10: Network programming 1

INSU YUN (윤인수)

School of Electrical Engineering, KAIST

[Slides from 15-213: Introduction to Computer Systems at CMU]

Computer Networks

- A ***network*** is a hierarchical system of boxes and wires organized by geographical proximity
 - LAN (Local Area Network) spans a building or campus
 - Ethernet is most prominent example
 - WAN (Wide Area Network) spans country or world
 - Typically high-speed point-to-point (mostly optical) links
 - Also: SAN (Storage area network), MAN (Metropolitan), etc., etc.
- An ***internetwork (internet)*** is an interconnected set of networks
 - The Global IP Internet (uppercase “I”) is the most famous example of an internet (lowercase “i”)
- Let’s see how an internet is built from the ground up



The ARPANET in December 1969

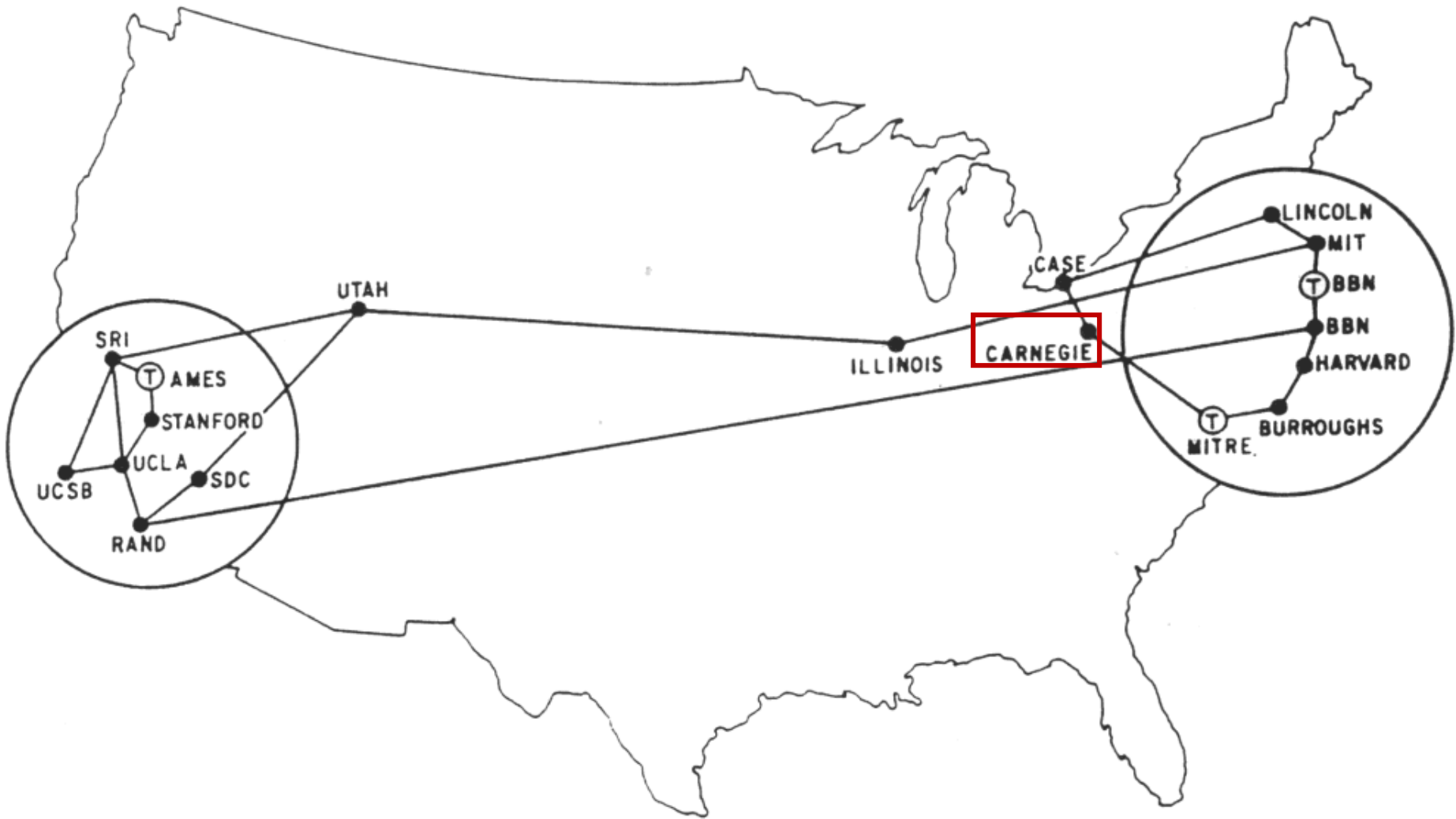

The ARPANET in December 1970

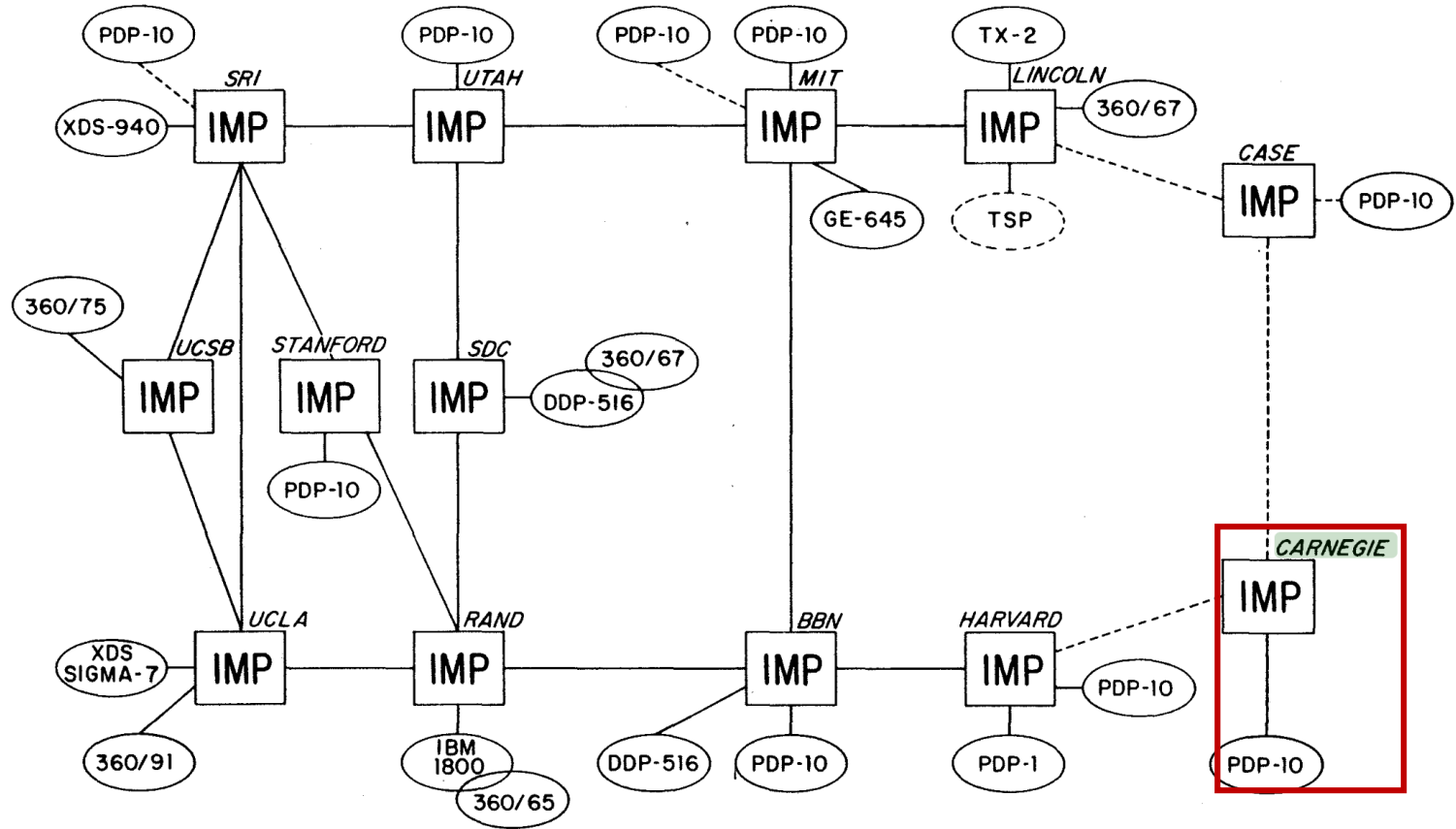

ARPA NET, DECEMBER 1970

ARPANET LOGICAL MAP, MARCH 1977

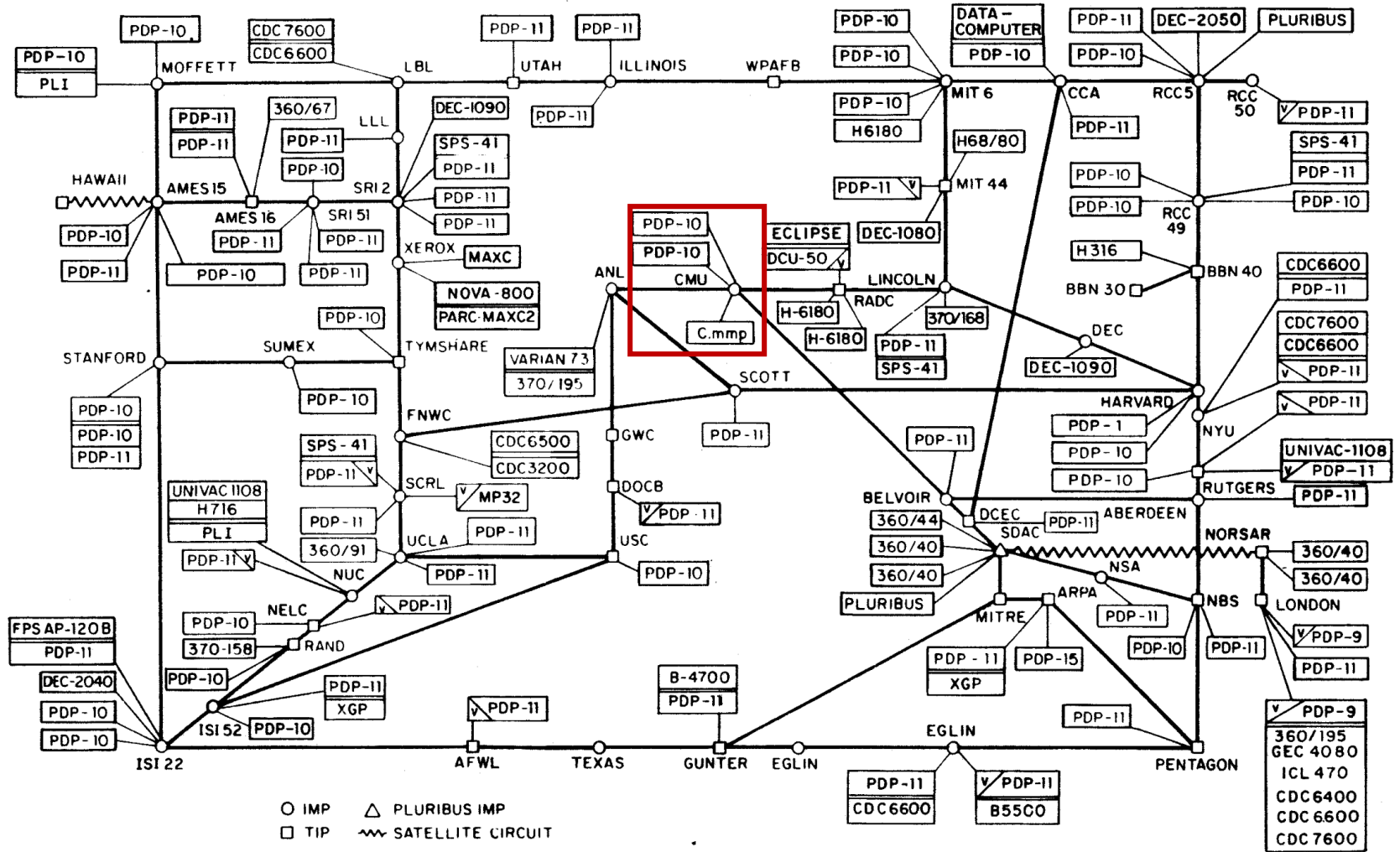

(PLEASE NOTE THAT WHILE THIS MAP SHOWS THE HOST POPULATION OF THE NETWORK ACCORDING TO THE BEST INFORMATION OBTAINABLE, NO CLAIM CAN BE MADE FOR ITS ACCURACY)

SUBMARINE CABLE MAP 2022

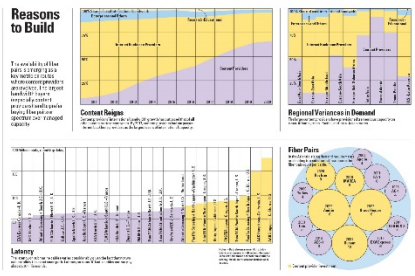
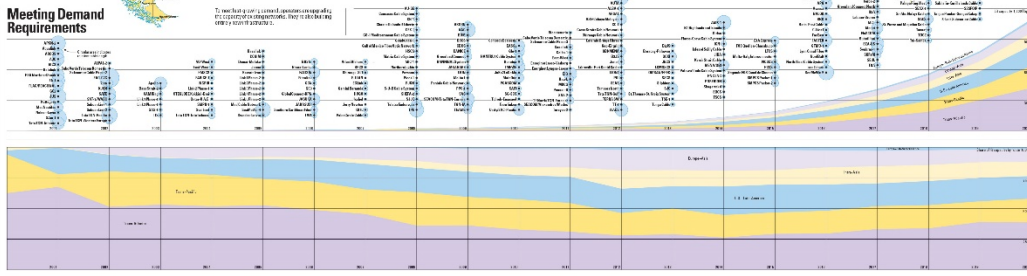
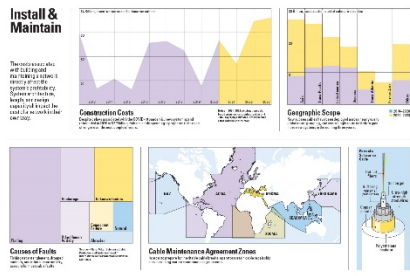
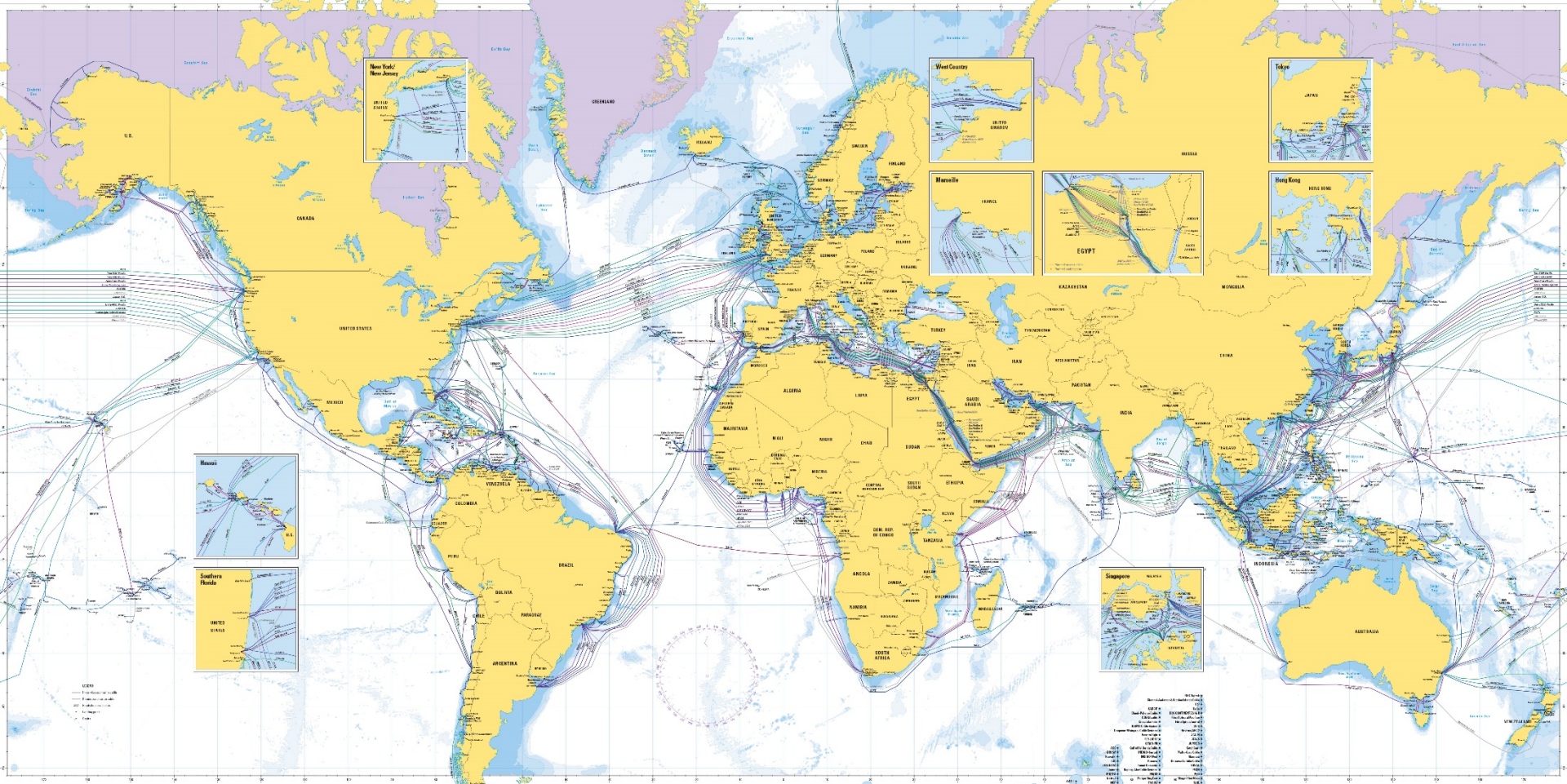

© 2022 TeleGeography. All rights reserved. This document is confidential and intended solely for the individual named. It is not to be distributed, copied, or used for any other purpose without the express written consent of TeleGeography. The information contained herein is subject to change without notice.

A Map of 460 Billion Device Connections to the Internet collected by the Carna Botnet

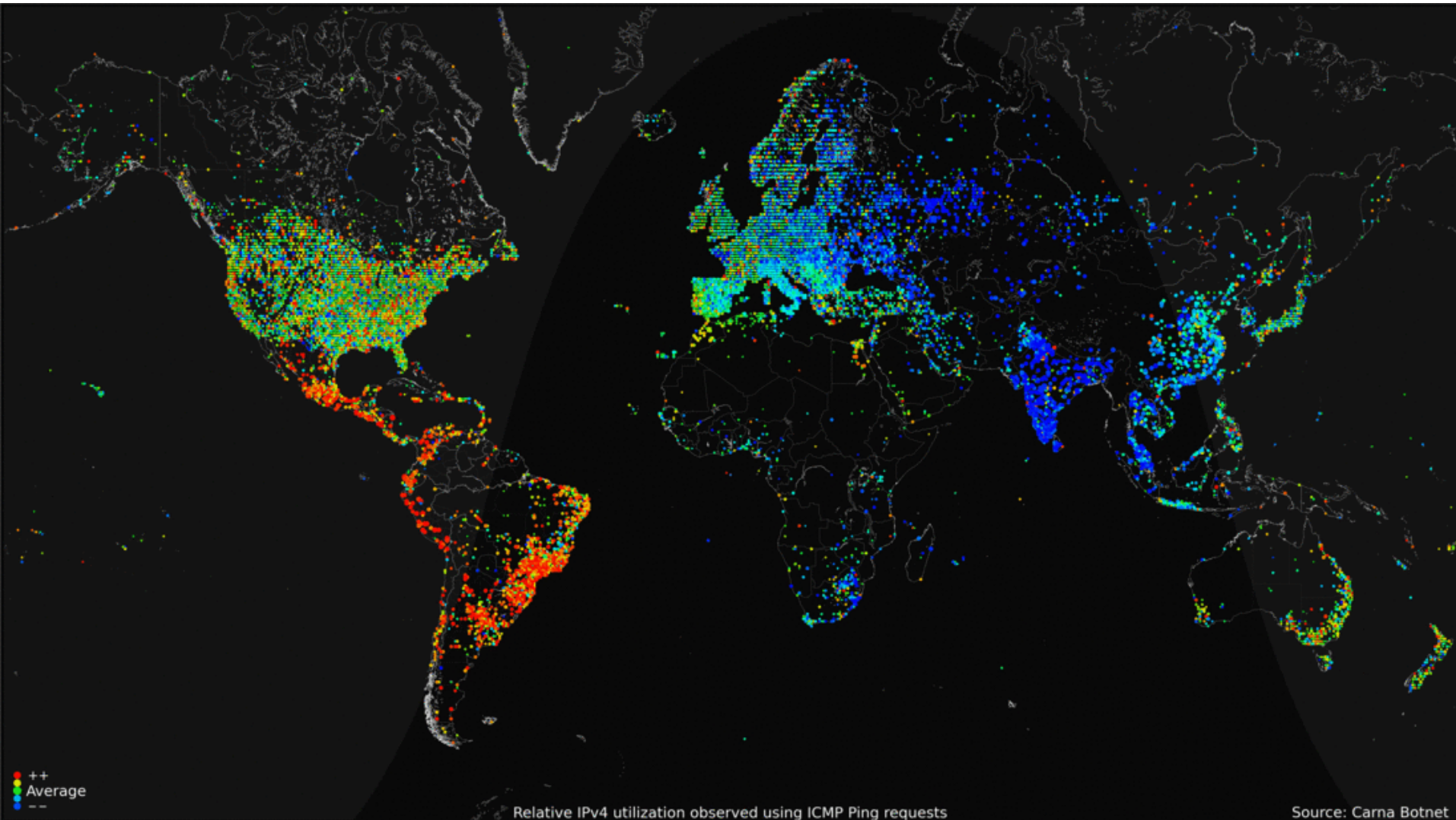

Hardware Organization of a Network Host

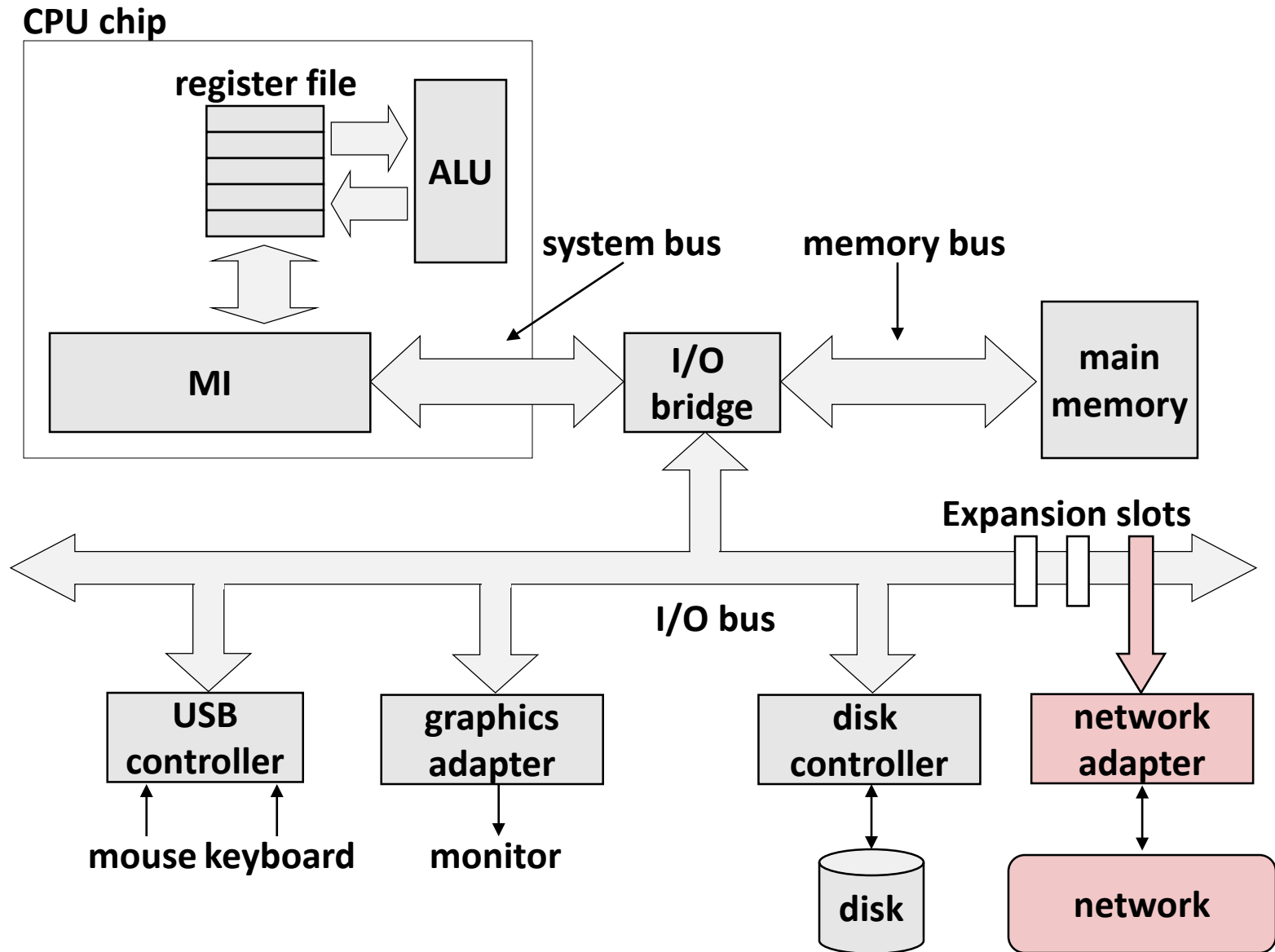

Old Lowest Level: Ethernet Segment

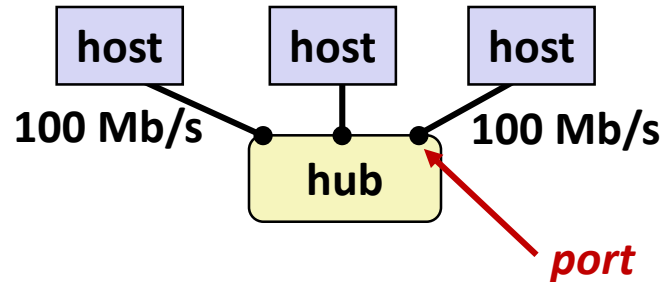

- Ethernet segment consists of a collection of *hosts* connected by wires (twisted pairs) to a *hub*
 - Spans room or floor in a building
 - Operation
 - Each Ethernet adapter has a unique 48-bit address (MAC address)
 - E.g., 00:16:ea:e3:54:e6
 - Hosts send bits to any other host in chunks called *frames*
 - Hub slavishly copies each bit from each port to every other port
 - Every host sees every bit
- [Note: Hubs are obsolete. Bridges (switches, routers) became cheap enough to replace them]

Next Level: Bridged Ethernet Segment

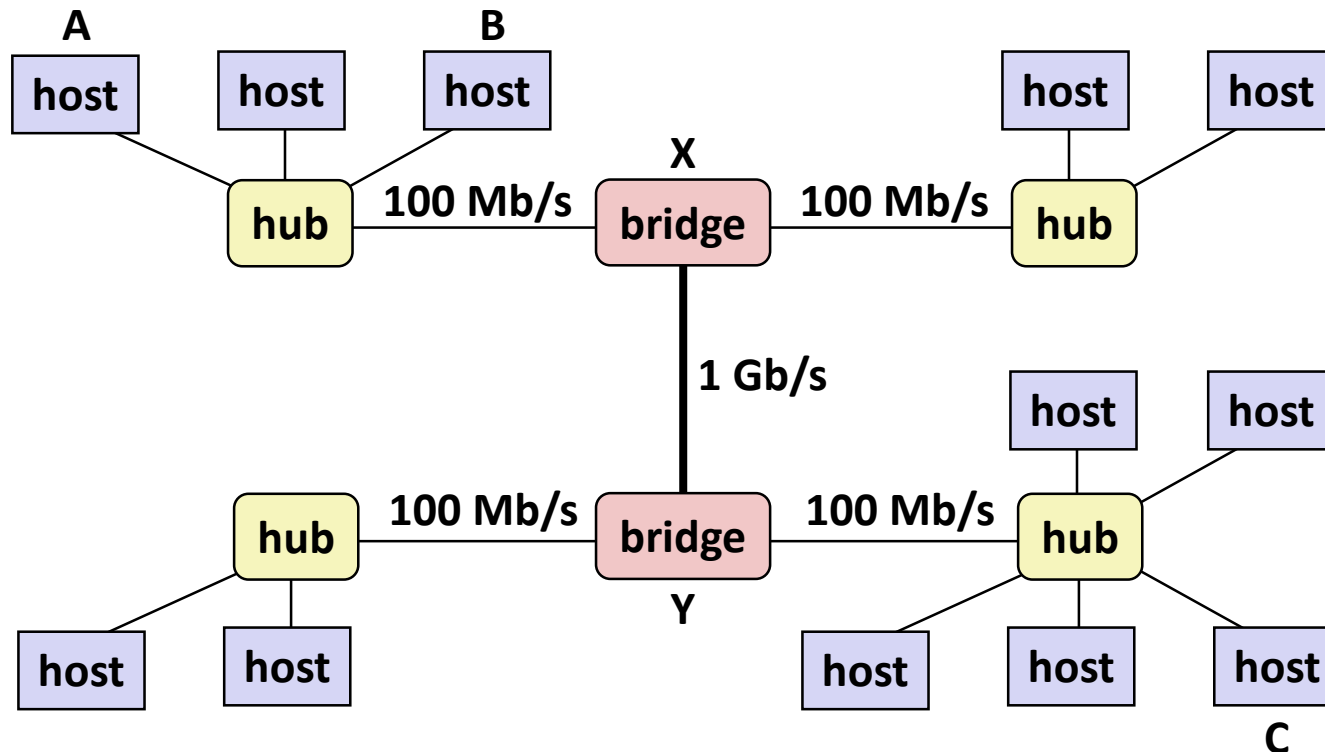

- Spans building or campus
- Bridges cleverly learn which hosts are reachable from which ports and then selectively copy frames from port to port

Conceptual View of LANs

- For simplicity, hubs, bridges, and wires are often shown as a collection of hosts attached to a single wire:



Next Level: internets

- Multiple incompatible LANs can be physically connected by specialized computers called *routers*
- The connected networks are called an *internet* (lower case)

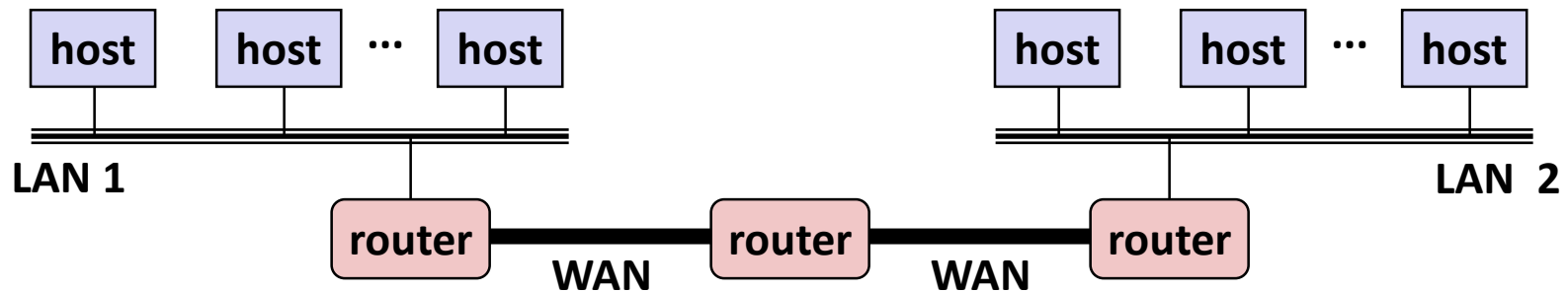

LAN 1 and LAN 2 might be completely different, totally incompatible (e.g., Ethernet, Fibre Channel, 802.11, T1-links, DSL, ...)*

Logical Structure of an internet

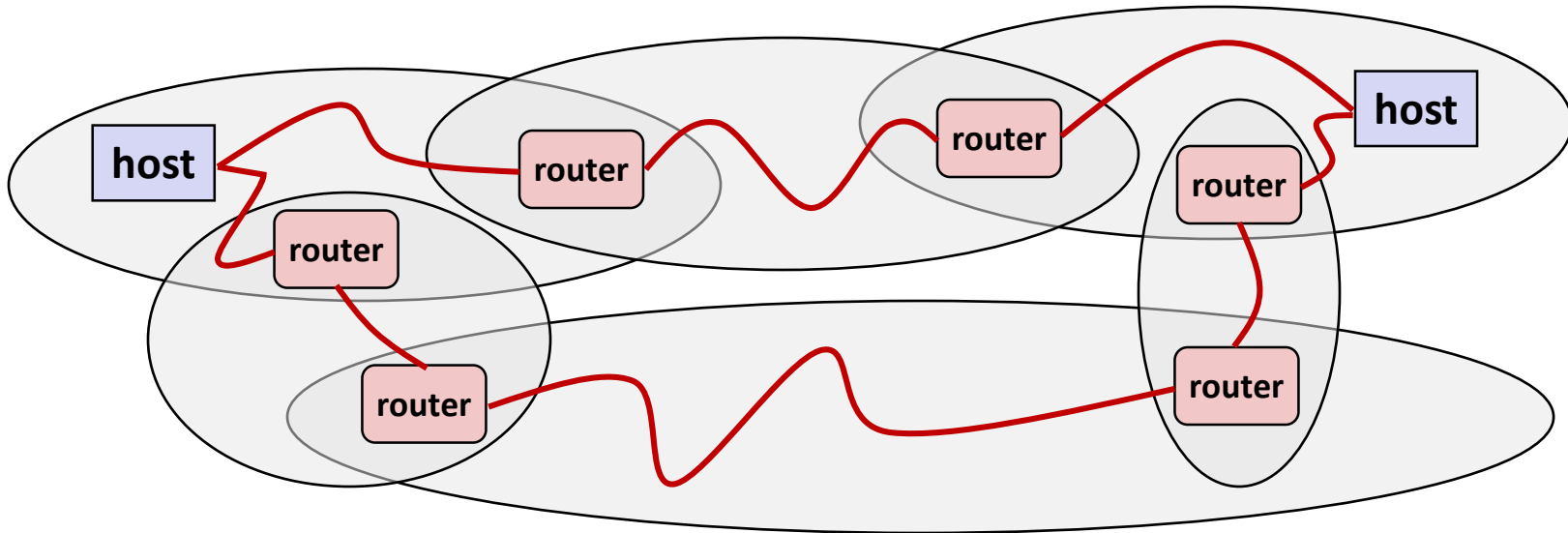

- **Ad hoc interconnection of networks**
 - No particular topology
 - Vastly different router & link capacities
- **Send packets from source to destination by hopping through networks**
 - Router forms bridge from one network to another
 - Different packets may take different routes

The Notion of an internet Protocol

- How is it possible to send bits across incompatible LANs and WANs?
- Solution: *protocol* software running on each host and router
 - Protocol is a set of rules that governs how hosts and routers should cooperate when they transfer data from network to network.
 - Smooths out the differences between the different networks

What Does an internet Protocol Do?

■ Provides a *naming scheme*

- An internet protocol defines a uniform format for *host addresses*
- Each host (and router) is assigned at least one of these internet addresses that uniquely identifies it

■ Provides a *delivery mechanism*

- An internet protocol defines a standard transfer unit (*packet*)
- Packet consists of *header* and *payload*
 - Header: contains info such as packet size, source and destination addresses
 - Payload: contains data bits sent from source host

Transferring internet Data Via Encapsulation

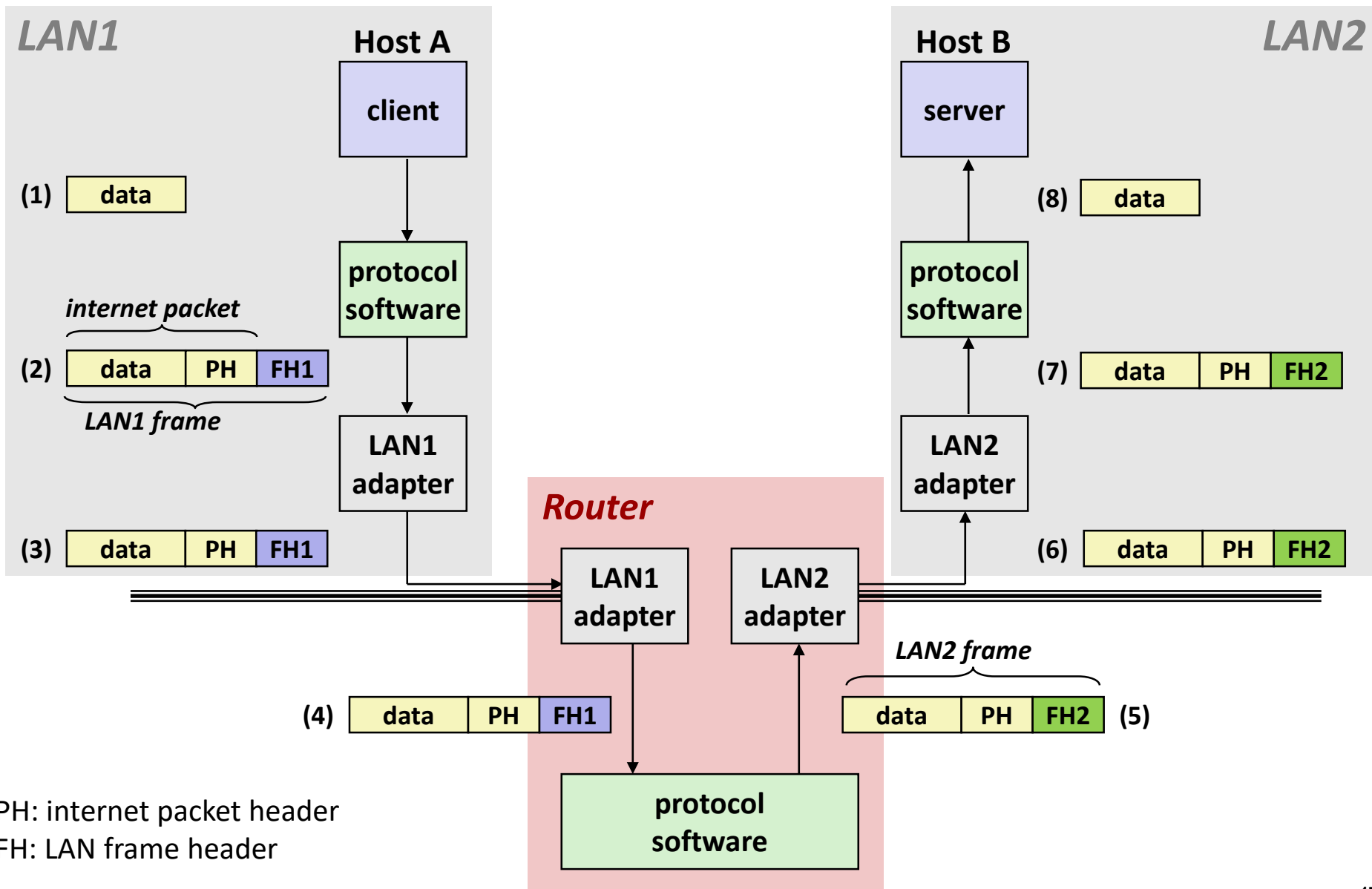

Other Issues

- **We are glossing over a number of important questions:**
 - What if different networks have different maximum frame sizes? (segmentation)
 - How do routers know where to forward frames?
 - How are routers informed when the network topology changes?
 - What if packets get lost?

- **These (and other) questions are addressed by the area of systems known as *computer networking***

Global IP Internet (upper case)

- Most famous example of an internet
- Based on the TCP/IP protocol family
 - IP (Internet Protocol)
 - Provides *basic naming scheme* and unreliable *delivery capability* of packets (datagrams) from *host-to-host*
 - UDP (User Datagram Protocol)
 - Uses IP to provide *unreliable* datagram delivery from *process-to-process*
 - TCP (Transmission Control Protocol)
 - Uses IP to provide *reliable* byte streams from *process-to-process* over *connections*
- Accessed via a mix of Unix file I/O and functions from the *sockets interface*

Basic Internet Components

■ Internet backbone:

- collection of routers (nationwide or worldwide) connected by high-speed point-to-point networks

■ Internet Exchange Points (IXP):

- router that connects multiple backbones (often referred to as peers)
- Also called Network Access Points (NAP)

■ Regional networks:

- smaller backbones that cover smaller geographical areas (e.g., cities or states)

■ Point of presence (POP):

- machine that is connected to the Internet

■ Internet Service Providers (ISPs):

- provide dial-up or direct access to POPs

Internet Connection Hierarchy

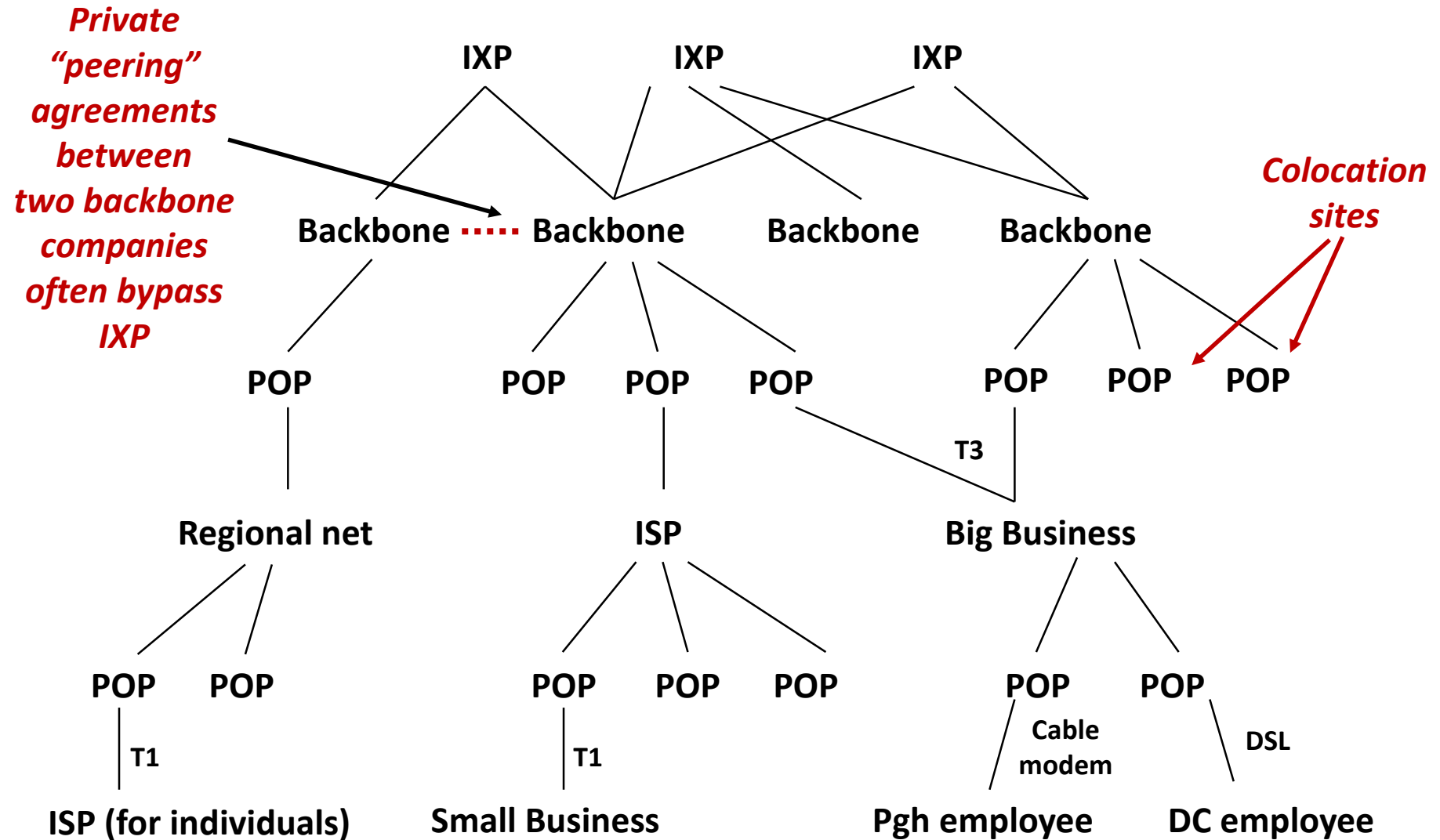

Hardware and Software Organization of an Internet Application

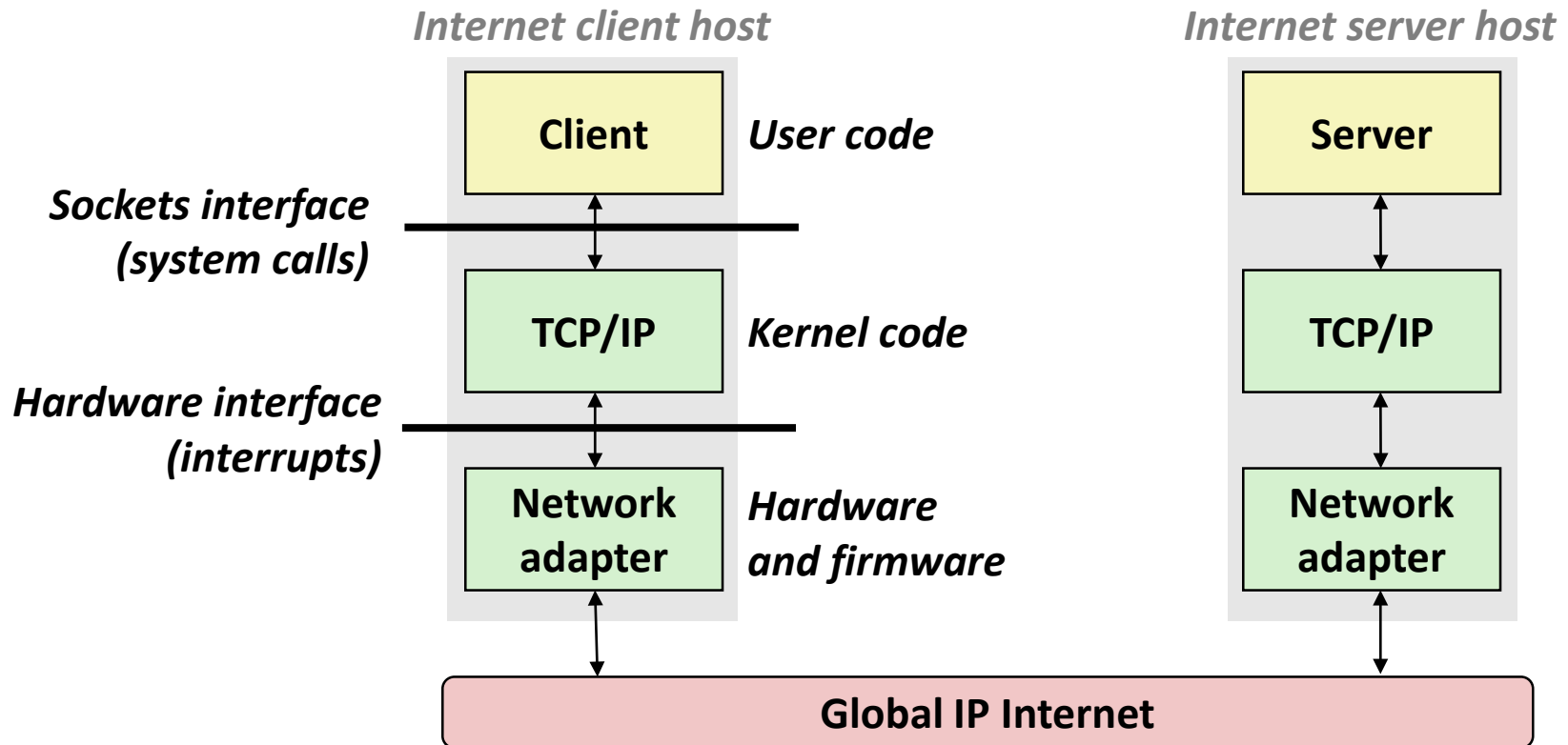

A Programmer's View of the Internet

1. Hosts are mapped to a set of 32-bit *IP addresses*

- 128.2.203.179
- 127.0.0.1 (always *localhost*)

2. As a convenience for humans, the Domain Name System maps a set of identifiers called Internet *domain names* to IP addresses:

- www.cs.cmu.edu “resolves to” 128.2.217.3

3. A process on one Internet host can communicate with a process on another Internet host over a *connection*

Aside: IPv4 and IPv6

- **IPv4 (Internet Protocol version 4) specified 1981**
 - 32-bit host addresses (192.0.2.43)
 - Known to not be enough for everyone since ~1990
- **IPv6 (Internet Protocol version 6) specified 1996**
 - 128-bit addresses (2001:0db8:0:0:0:0:cafe:la7e)
 - Intended to replace IPv4
 - Very slow adoption due to need to replace routers (CMU's network doesn't support IPv6 at all!)
- **Application programmers mostly don't have to care**
 - Sockets API makes it easy to write code that seamlessly uses either, as necessary

IPv6 traffic to Google

<https://www.google.com/intl/en/ipv6/statistics.html>

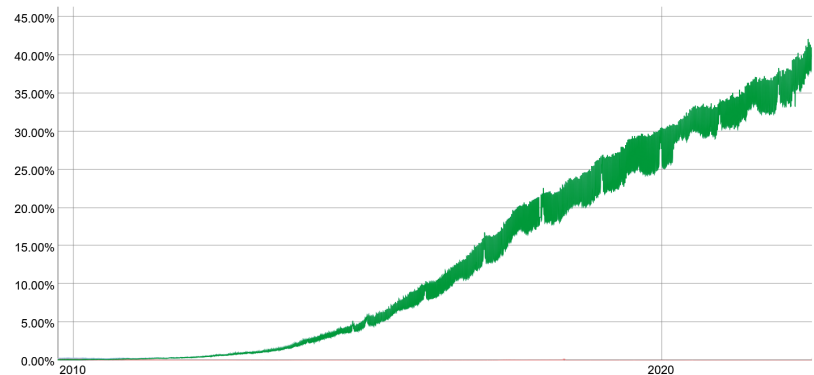

(1) IP Addresses

- **32-bit IP addresses are stored in an *IP address struct***
 - IP addresses are always stored in memory in *network byte order* (big-endian byte order)
 - True in general for any integer transferred in a packet header from one machine to another.
 - E.g., the port number used to identify an Internet connection.

```
/* Internet address structure */
struct in_addr {
    uint32_t  s_addr; /* network byte order (big-endian) */
};
```

Dotted Decimal Notation

- By convention, each byte in a 32-bit IP address is represented by its decimal value and separated by a period
 - IP address: `0x8002C2F2` = `128.2.194.242`
- Use `getaddrinfo` and `getnameinfo` functions (described later) to convert between IP addresses and dotted decimal format.

(2) Internet Domain Names

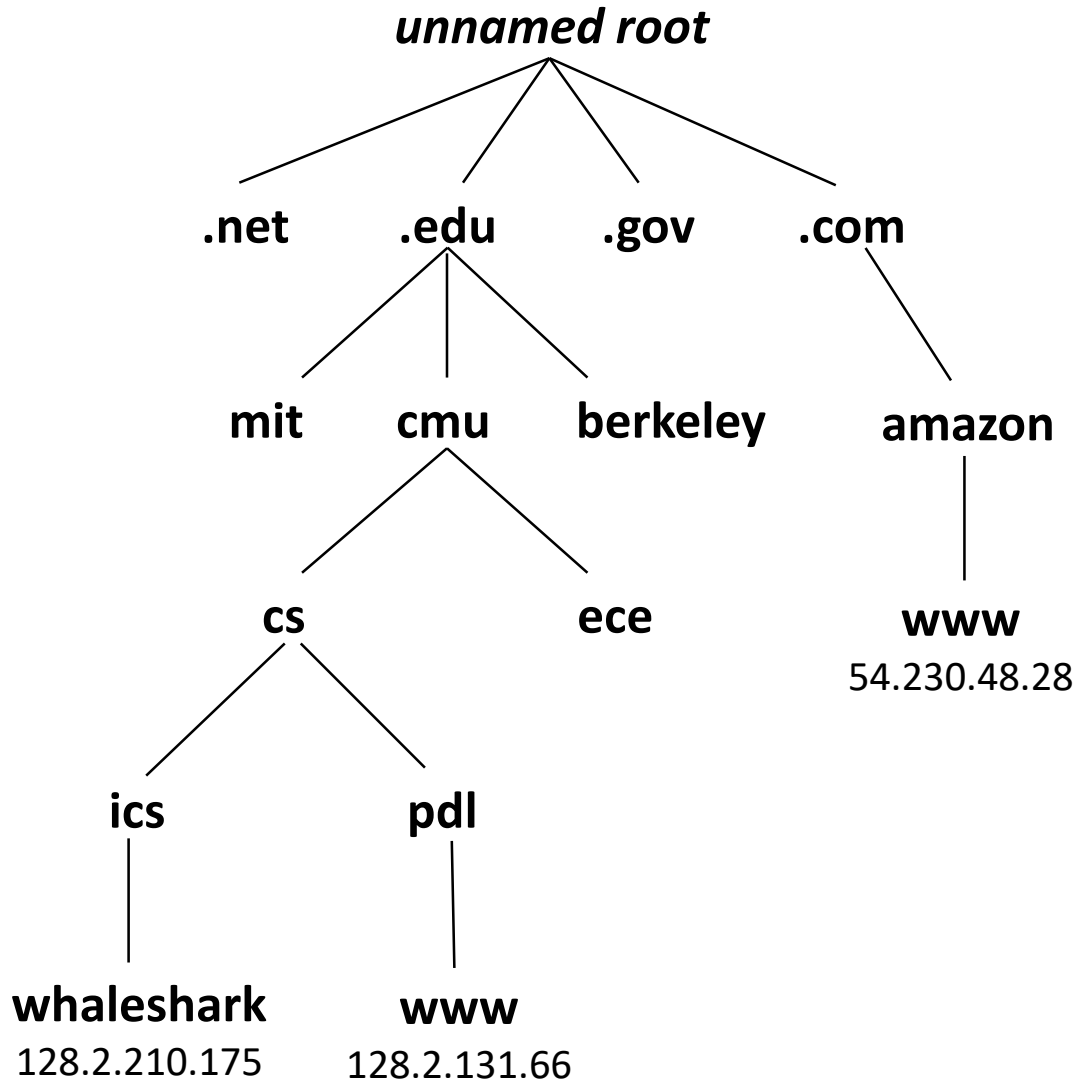

First-level domain names

Second-level domain names

Third-level domain names

.space	.store	.stream	.studio
.study	.style	.supplies	.supply
.support	.surf	.surgery	.sydney
.systems	.taipei	.tattoo	.tax
.taxi	.team	.tech	.technology
.tennis	.theater	.theatre	.tienda
.tips	.tires	.tirol	.today
.tokyo	.tools	.top	.tours
.town	.toys	.trade	.trading
.training	.tube	.university	.uno
.vacations	.vegas	.ventures	.versicherung
.vet	.viajes	.video	.villas
.vin	.vip	.vision	.vlaanderen
.vodka	.vote	.voting	.voto
.voyage	.wales	.wang	.watch
.webcam	.website	.wed	.wedding
.whoswho	.wien	.wiki	.win
.wine	.work	.works	.world
.wtf	.在线	.移动	.онлайн
.сайт	.сайт	.org	.中文网
.संगठन	.机构	.みんな	.游戏
.企业	.xyz	.yoga	.yokohama
.zone			

Domain Naming System (DNS)

- The Internet maintains a mapping between IP addresses and domain names in a worldwide distributed database called **DNS**
- Conceptually, programmers can view the DNS database as a collection of millions of *host entries*.
 - Each host entry defines the mapping between a set of domain names and IP addresses.
 - In a mathematical sense, a host entry is an equivalence class of domain names and IP addresses.

Properties of DNS Mappings

- Can explore properties of DNS mappings using `nslookup`
 - (Output edited for brevity)

- Each host has a locally defined domain name `localhost` which always maps to the *loopback address* `127.0.0.1`

```
linux> nslookup localhost
Address: 127.0.0.1
```

- Use `hostname` to determine real domain name of local host:

```
linux> hostname
whaleshark.ics.cs.cmu.edu
```

Properties of DNS Mappings (cont)

- **Simple case: one-to-one mapping between domain name and IP address:**

```
linux> nslookup whaleshark.ics.cs.cmu.edu  
Address: 128.2.210.175
```

- **Multiple domain names mapped to the same IP address:**

```
linux> nslookup cs.mit.edu  
Address: 18.25.0.23  
linux> nslookup eecs.mit.edu  
Address: 18.25.0.23
```

- **And backwards:**

```
linux> nslookup 18.25.0.23  
23.0.25.18.in-addr.arpa      name = eecs.mit.edu.
```

Properties of DNS Mappings (cont)

- Multiple domain names mapped to multiple IP addresses:

```
linux> nslookup www.twitter.com
Address: 104.244.42.65
Address: 104.244.42.129
Address: 104.244.42.193
Address: 104.244.42.1
```

```
linux> nslookup www.twitter.com
Address: 104.244.42.129
Address: 104.244.42.65
Address: 104.244.42.193
Address: 104.244.42.1
```

- Some valid domain names don't map to any IP address:

```
linux> nslookup ics.cs.cmu.edu
(No Address given)
```

A Client-Server Transaction

- Most network applications are based on the client-server model:
 - A **server** process and one or more **client** processes
 - Server manages some **resource**
 - Server provides **service** by manipulating resource for clients
 - Server activated by request from client (vending machine analogy)

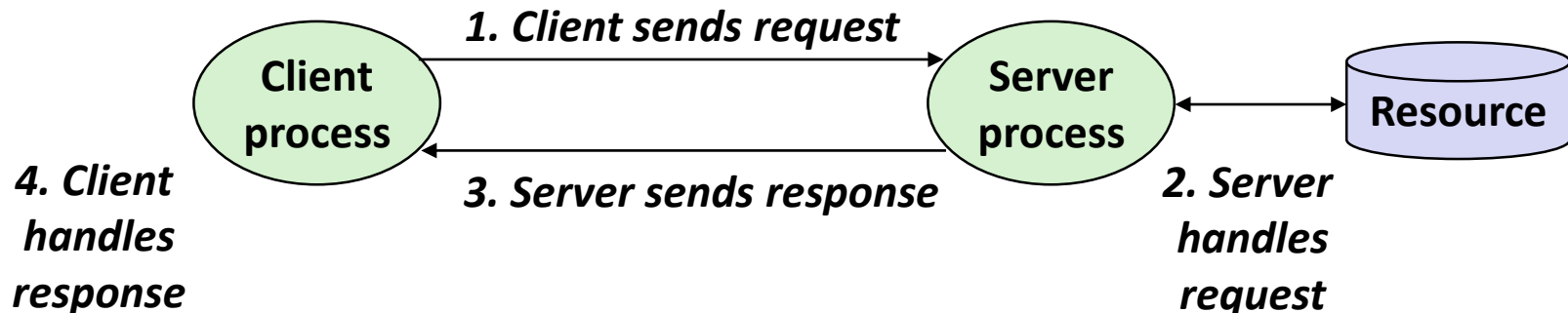

Note: clients and servers are processes running on hosts (can be the same or different hosts)

(3) Internet Connections

- Clients and servers most often communicate by sending streams of bytes over TCP *connections*. Each connection is:
 - *Point-to-point*: connects a pair of processes.
 - *Full-duplex*: data can flow in both directions at the same time,
 - *Reliable*: stream of bytes sent by the source is eventually received by the destination in the same order it was sent.
- A *socket* is an endpoint of a connection
 - *Socket address* is an `IPAddress:port` pair
- A *port* is a 16-bit integer that identifies a process:
 - *Ephemeral port*: Assigned automatically by client kernel when client makes a connection request.
 - *Well-known port*: Associated with some *service* provided by a server (e.g., port 80 is associated with Web servers)

Well-known Service Names and Ports

- Popular services have permanently assigned *well-known ports* and corresponding *well-known service names*:
 - echo servers: echo 7
 - ftp servers: ftp 21
 - ssh servers: ssh 22
 - email servers: smtp 25
 - Unencrypted Web servers: http 80
 - SSL/TLS encrypted Web: https 443
- Mappings between well-known ports and service names is contained in the file `/etc/services` on each Linux machine.

Anatomy of a Connection

- A connection is uniquely identified by the socket addresses of its endpoints (*socket pair*)
 - (cliaddr:cliport, servaddr:servport)

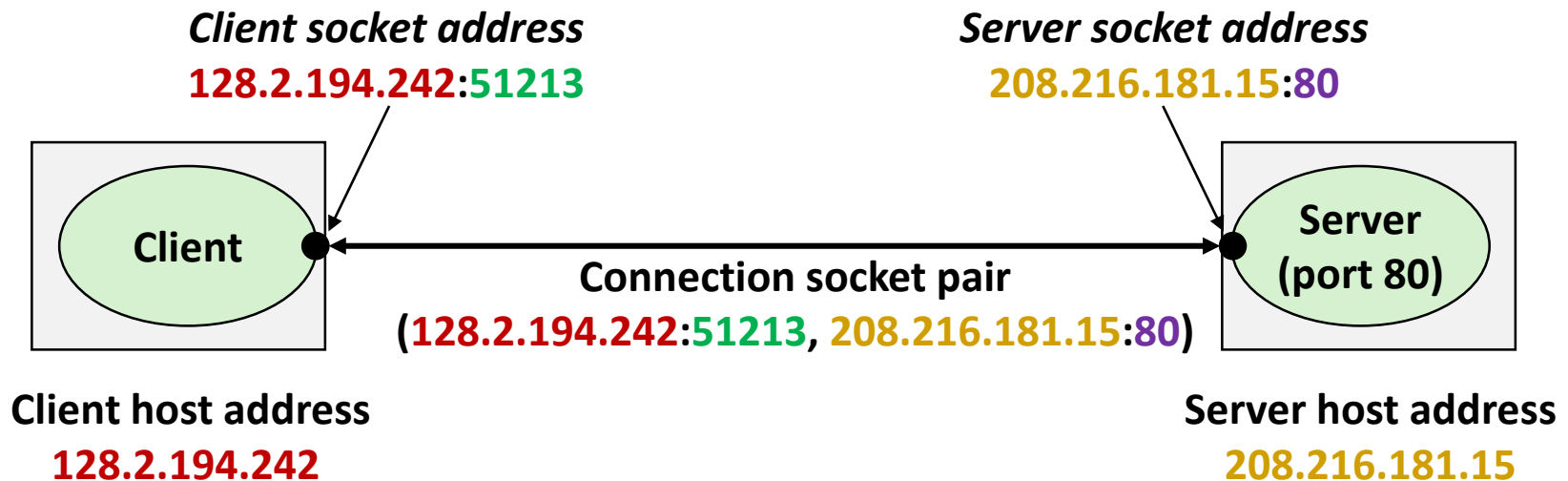

51213 is an ephemeral port allocated by the kernel

80 is a well-known port associated with Web servers

Using Ports to Identify Services

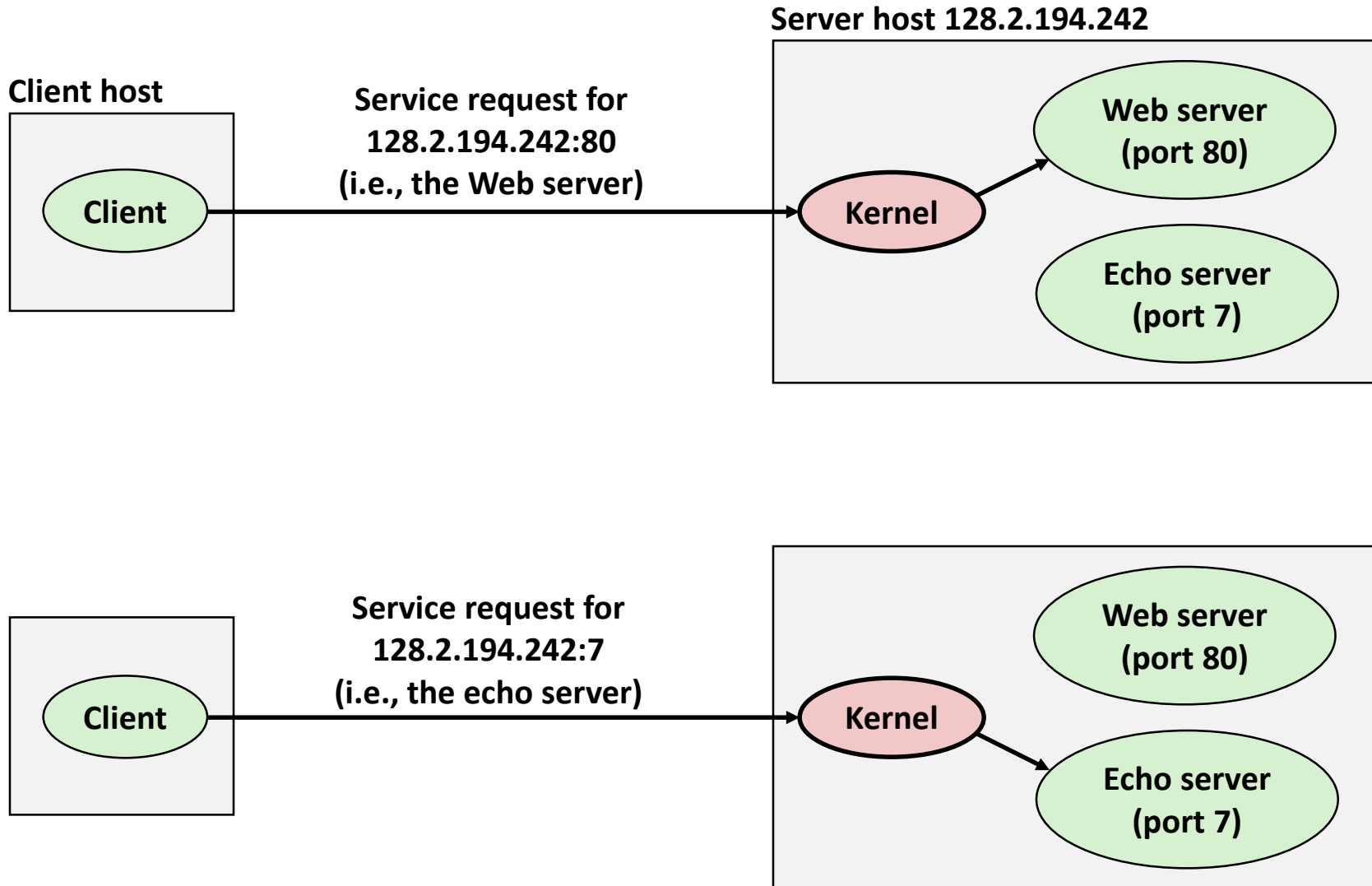

Sockets Interface

- **Set of system-level functions used in conjunction with Unix I/O to build network applications.**
- **Created in the early 80's as part of the original Berkeley distribution of Unix that contained an early version of the Internet protocols.**
- **Available on all modern systems**
 - Unix variants, Windows, OS X, IOS, Android, ARM

Sockets

■ What is a socket?

- To the kernel, a socket is an endpoint of communication
- To an application, a socket is a file descriptor that lets the application read/write from/to the network
- Using the FD abstraction lets you reuse code & interfaces

■ Clients and servers communicate with each other by reading from and writing to socket descriptors

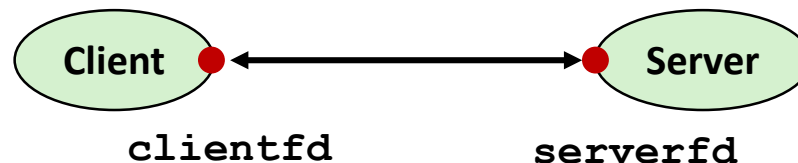

- The main distinction between regular file I/O and socket I/O is how the application “opens” the socket descriptors

Socket Programming Example

- **Echo server and client**
- **Server**
 - Accepts connection request
 - Repeats back lines as they are typed
- **Client**
 - Requests connection to server
 - Repeatedly:
 - Read line from terminal
 - Send to server
 - Read reply from server
 - Print line to terminal

Echo Server/Client Session Example

Client

```
bambooshark: ./echoclient whaleshark.ics.cs.cmu.edu 6616      (A)
This line is being echoed                                     (B)
This line is being echoed
This one is, too                                           (C)
This one is, too
^D
bambooshark: ./echoclient whaleshark.ics.cs.cmu.edu 6616      (D)
This one is a new connection                               (E)
This one is a new connection
^D
```

Server

```
whaleshark: ./echoserveri 6616
Connected to (BAMBOOSHARK.ICS.CS.CMU.EDU, 33707)          (A)
server received 26 bytes                                   (B)
server received 17 bytes                                   (C)
Connected to (BAMBOOSHARK.ICS.CS.CMU.EDU, 33708)          (D)
server received 29 bytes                                   (E)
```

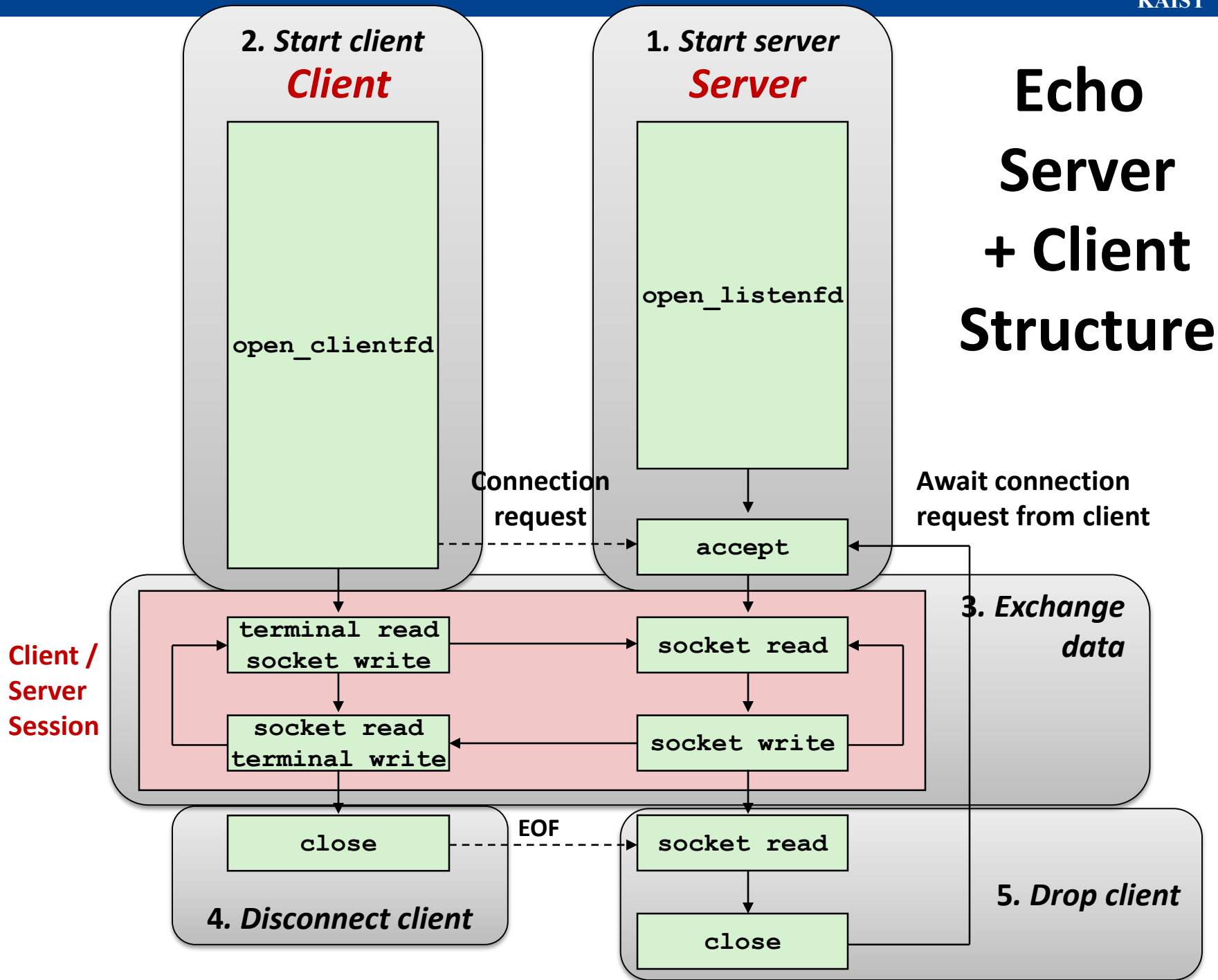

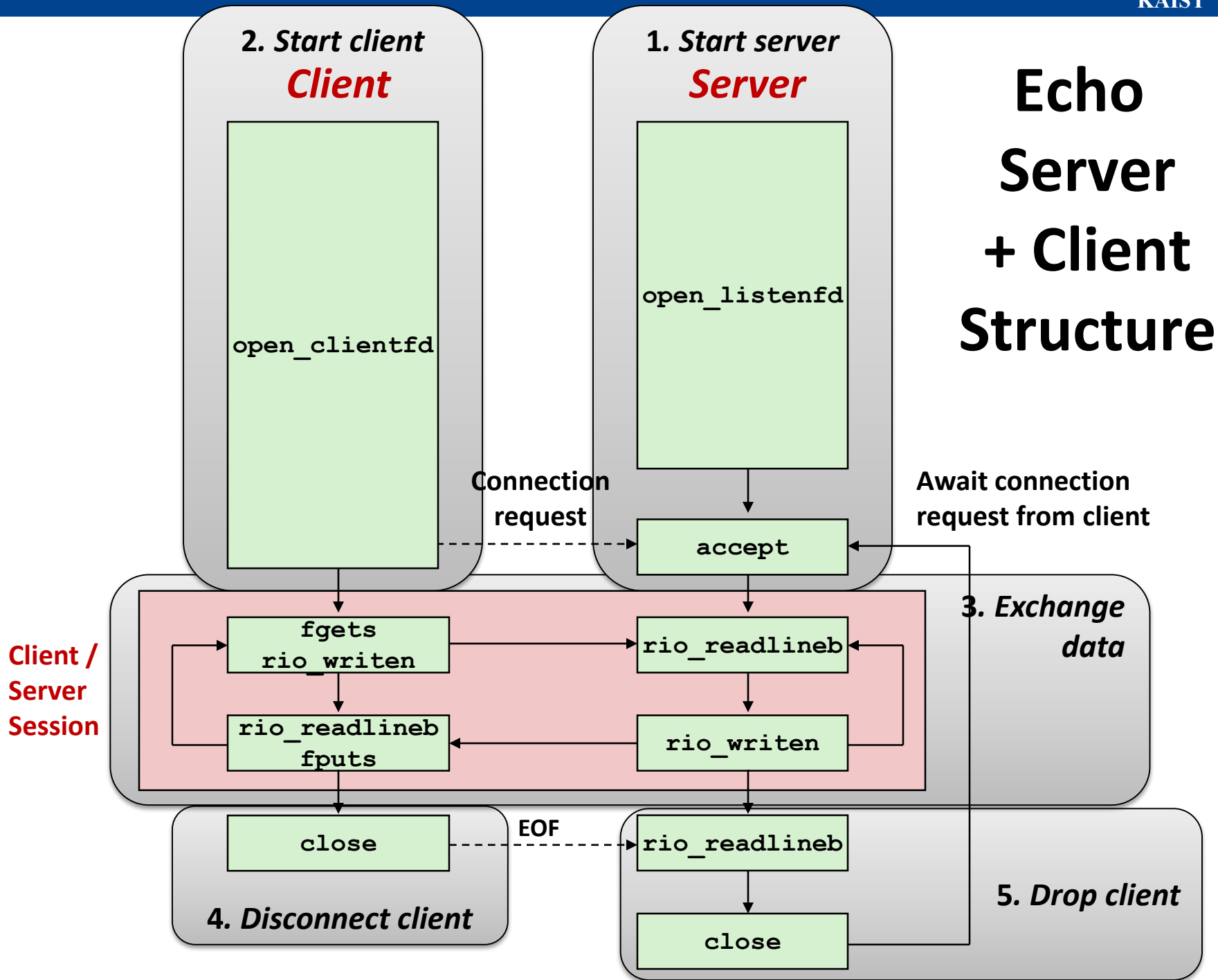

Recall: Unbuffered RIO Input/Output

- Same interface as Unix `read` and `write`
- Especially useful for transferring data on network sockets

```
#include "csapp.h"
```

```
ssize_t rio_readn(int fd, void *usrbuf, size_t n);  
ssize_t rio_writen(int fd, void *usrbuf, size_t n);
```

Return: num. bytes transferred if OK, 0 on EOF (`rio_readn` only), -1 on error

- `rio_readn` returns short count only if it encounters EOF
 - Only use it when you know how many bytes to read
- `rio_writen` never returns a short count
- Calls to `rio_readn` and `rio_writen` can be interleaved arbitrarily on the same descriptor

Recall: Buffered RIO Input Functions

- Efficiently read text lines and binary data from a file partially cached in an internal memory buffer

```
#include "csapp.h"

void rio_readinitb(rio_t *rp, int fd);

ssize_t rio_readlineb(rio_t *rp, void *usrbuf, size_t maxlen);
ssize_t rio_readnb(rio_t *rp, void *usrbuf, size_t n);
```

Return: num. bytes read if OK, 0 on EOF, -1 on error

- **rio_readlineb** reads a *text line* of up to **maxlen** bytes from file **fd** and stores the line in **usrbuf**
 - Especially useful for reading text lines from network sockets
- Stopping conditions
 - **maxlen** bytes read
 - EOF encountered
 - Newline ('\n') encountered

Echo Client: Main Routine

```
#include "csapp.h"

int main(int argc, char **argv)
{
    int clientfd;
    char *host, *port, buf[MAXLINE];
    rio_t rio;

    host = argv[1];
    port = argv[2];

    clientfd = Open_clientfd(host, port);
    Rio_readinitb(&rio, clientfd);

    while (Fgets(buf, MAXLINE, stdin) != NULL) {
        Rio_writen(clientfd, buf, strlen(buf));
        Rio_readlineb(&rio, buf, MAXLINE);
        Fputs(buf, stdout);
    }
    Close(clientfd);
    exit(0);
}
```

echoclient.c

Echo Server + Client Structure

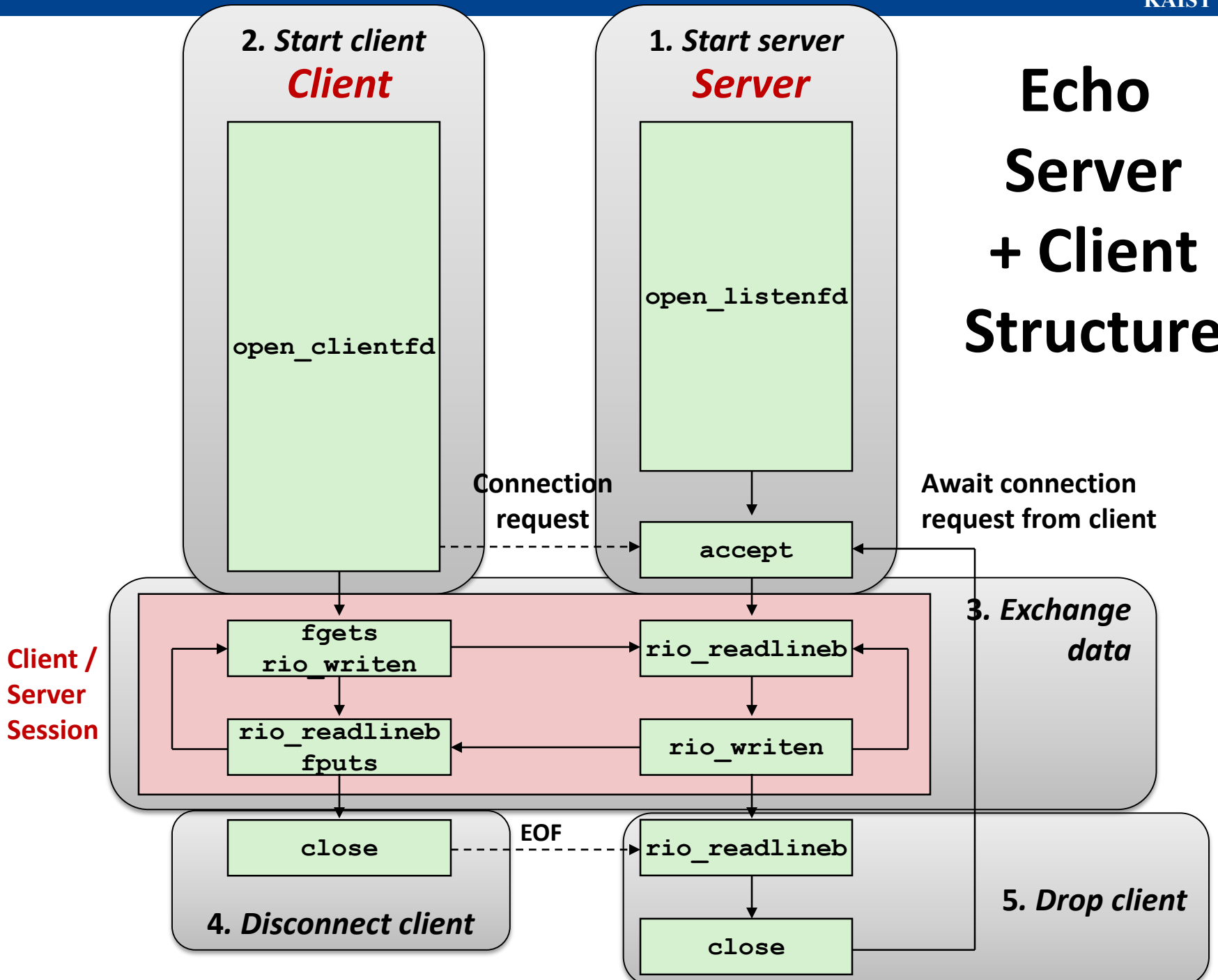

Iterative Echo Server: Main Routine

```
#include "csapp.h"
void echo(int connfd);

int main(int argc, char **argv)
{
    int listenfd, connfd;
    socklen_t clientlen;
    struct sockaddr_storage clientaddr; /* Enough room for any addr */
    char client_hostname[MAXLINE], client_port[MAXLINE];

    listenfd = Open_listenfd(argv[1]);
    while (1) {
        clientlen = sizeof(struct sockaddr_storage); /* Important! */
        connfd = Accept(listenfd, (SA *)&clientaddr, &clientlen);
        Getnameinfo((SA *)&clientaddr, clientlen,
                    client_hostname, MAXLINE, client_port, MAXLINE, 0);
        printf("Connected to (%s, %s)\n", client_hostname, client_port);
        echo(connfd);
        Close(connfd);
    }
    exit(0);
}
```

echoserveri.c

Echo Server: echo function

- The server uses RIO to read and echo text lines until EOF (end-of-file) condition is encountered.
 - EOF condition caused by client calling `close(clientfd)`

```
void echo(int connfd)
{
    size_t n;
    char buf[MAXLINE];
    rio_t rio;

    Rio_readinitb(&rio, connfd);
    while((n = Rio_readlineb(&rio, buf, MAXLINE)) != 0) {
        printf("server received %d bytes\n", (int)n);
        Rio_writen(connfd, buf, n);
    }
}
```

echo.c

Socket Address Structures

■ Generic socket address:

- For address arguments to **connect**, **bind**, and **accept** (*next lecture*)
- Necessary only because C did not have generic (**void ***) pointers when the sockets interface was designed
- For casting convenience, we adopt the Stevens convention:

```
typedef struct sockaddr SA;
```

```
struct sockaddr {  
    uint16_t  sa_family;    /* Protocol family */  
    char      sa_data[14]; /* Address data */  
};
```

sa_family

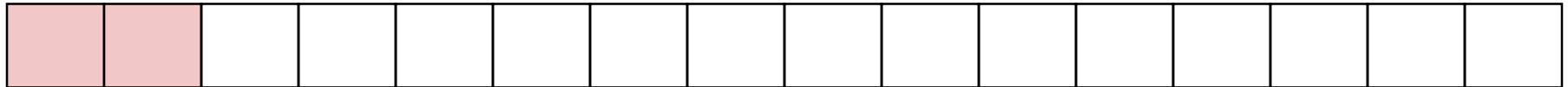

Family Specific

Socket Address Structures

■ Internet (IPv4) specific socket address:

- Must cast (`struct sockaddr_in *`) to (`struct sockaddr *`) for functions that take socket address arguments.

```

struct sockaddr_in {
    uint16_t      sin_family; /* Protocol family (always AF_INET) */
    uint16_t      sin_port;  /* Port num in network byte order */
    struct in_addr sin_addr; /* IP addr in network byte order */
    unsigned char sin_zero[8]; /* Pad to sizeof(struct sockaddr) */
};

```

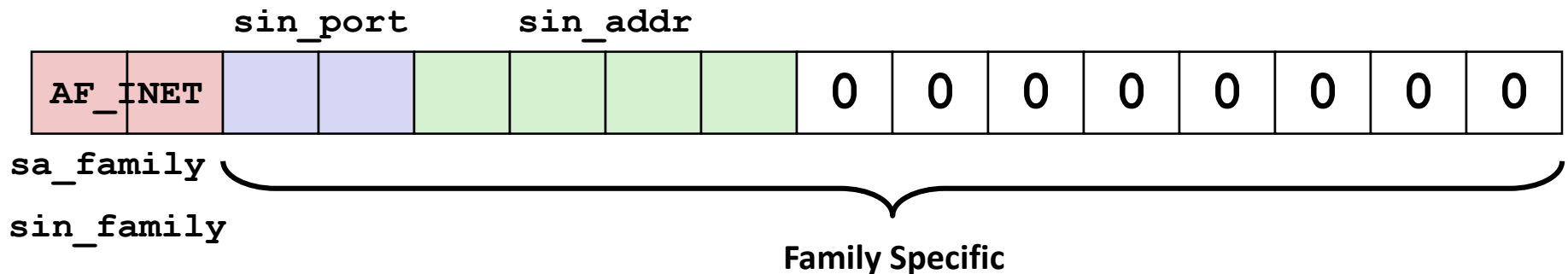

Host and Service Conversion: `getaddrinfo`

- `getaddrinfo` is the modern way to convert string representations of hostnames, host addresses, ports, and service names to socket address structures.
 - Replaces obsolete `gethostbyname` and `getservbyname` funcs.
- **Advantages:**
 - Reentrant (can be safely used by threaded programs).
 - Allows us to write portable protocol-independent code
 - Works with both IPv4 and IPv6
- **Disadvantages**
 - Somewhat complex
 - Fortunately, a small number of usage patterns suffice in most cases.

Host and Service Conversion: `getaddrinfo`

```
int getaddrinfo(const char *host,          /* Hostname or address */
               const char *service,      /* Port or service name */
               const struct addrinfo *hints, /* Input parameters */
               struct addrinfo **result); /* Output linked list */

void freeaddrinfo(struct addrinfo *result); /* Free linked list */

const char *gai_strerror(int errcode);    /* Return error msg */
```

- Given `host` and `service`, `getaddrinfo` returns `result` that points to a linked list of `addrinfo` structs, each of which points to a corresponding socket address struct, and which contains arguments for the sockets interface functions.
- **Helper functions:**
 - `freeaddrinfo` frees the entire linked list.
 - `gai_strerror` converts error code to an error message.

Linked List Returned by getaddrinfo

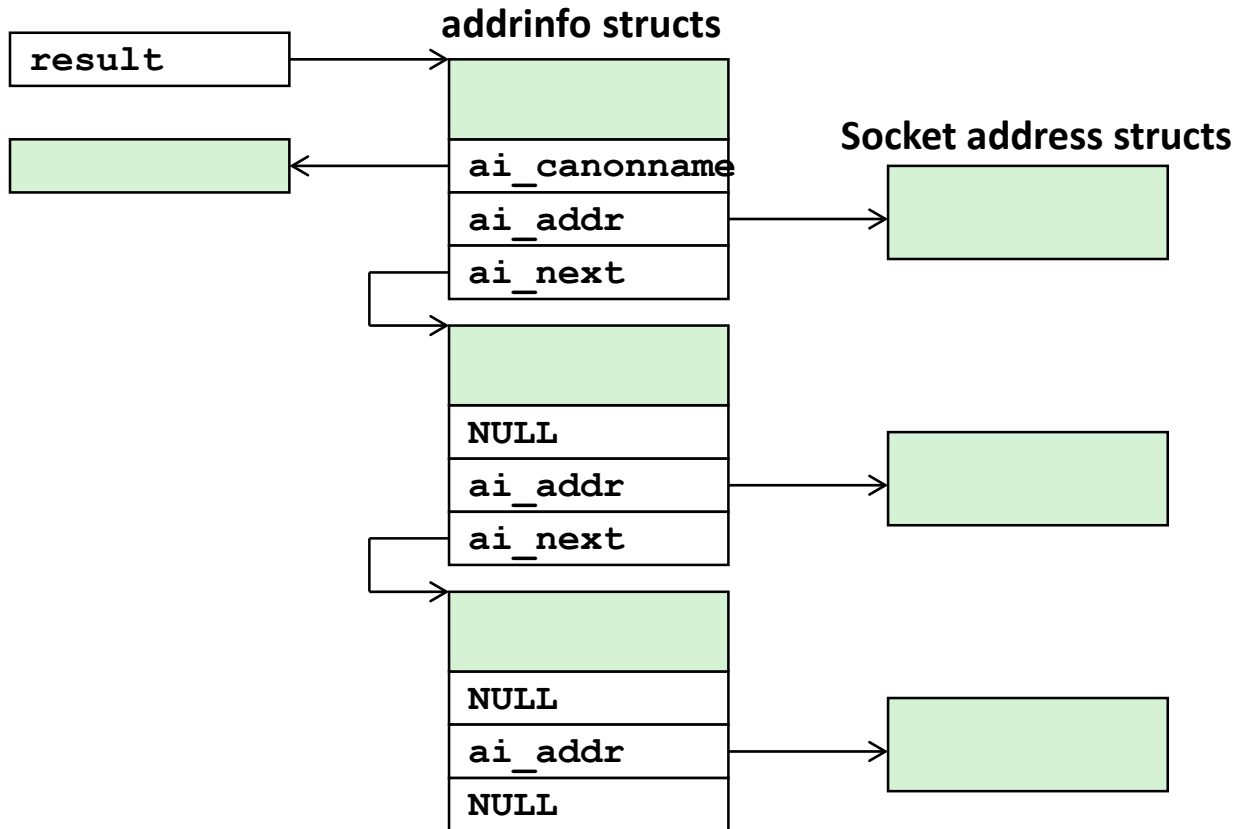

addrinfo Struct

```
struct addrinfo {
    int          ai_flags;      /* Hints argument flags */
    int          ai_family;    /* First arg to socket function */
    int          ai_socktype;  /* Second arg to socket function */
    int          ai_protocol;  /* Third arg to socket function */
    char        *ai_canonname; /* Canonical host name */
    size_t       ai_addrlen;   /* Size of ai_addr struct */
    struct sockaddr *ai_addr;  /* Ptr to socket address structure */
    struct addrinfo *ai_next;  /* Ptr to next item in linked list */
};
```

- Each addrinfo struct returned by getaddrinfo contains arguments that can be passed directly to socket function.
- Also points to a socket address struct that can be passed directly to connect and bind functions .

(socket, connect, bind to be discussed next lecture)

Host and Service Conversion: `getnameinfo`

- `getnameinfo` is the inverse of `getaddrinfo`, converting a socket address to the corresponding host and service.
 - Replaces obsolete `gethostbyaddr` and `getservbyport` funcs.
 - Reentrant and protocol independent.

```
int getnameinfo(const SA *sa, socklen_t salen, /* In: socket addr */
               char *host, size_t hostlen, /* Out: host */
               char *serv, size_t servlen, /* Out: service */
               int flags); /* optional flags */
```

Conversion Example

```
#include "csapp.h"

int main(int argc, char **argv)
{
    struct addrinfo *p, *listp, hints;
    char buf[MAXLINE];
    int rc, flags;

    /* Get a list of addrinfo records */
    memset(&hints, 0, sizeof(struct addrinfo));
    // hints.ai_family = AF_INET;          /* IPv4 only */
    hints.ai_socktype = SOCK_STREAM; /* Connections only */
    if ((rc = getaddrinfo(argv[1], NULL, &hints, &listp)) != 0) {
        fprintf(stderr, "getaddrinfo error: %s\n", gai_strerror(rc));
        exit(1);
    }
}
```

hostinfo.c

Conversion Example (cont)

```
/* Walk the list and display each IP address */
flags = NI_NUMERICHOST; /* Display address instead of name */
for (p = listp; p; p = p->ai_next) {
    Getnameinfo(p->ai_addr, p->ai_addrlen,
                buf, MAXLINE, NULL, 0, flags);
    printf("%s\n", buf);
}

/* Clean up */
Freeaddrinfo(listp);

exit(0);
}
```

hostinfo.c

Running hostinfo

```
whaleshark> ./hostinfo localhost  
127.0.0.1
```

```
whaleshark> ./hostinfo whaleshark.ics.cs.cmu.edu  
128.2.210.175
```

```
whaleshark> ./hostinfo twitter.com  
199.16.156.230  
199.16.156.38  
199.16.156.102  
199.16.156.198
```

```
whaleshark> ./hostinfo google.com  
172.217.15.110  
2607:f8b0:4004:802::200e
```

Next time

- Using `getaddrinfo` for host and service conversion
- Writing clients and servers
- Writing Web servers!
 - Activities 5 and 6